

Spectrel 121000/336

Long-Range Camera System with HR-video
Datasheet

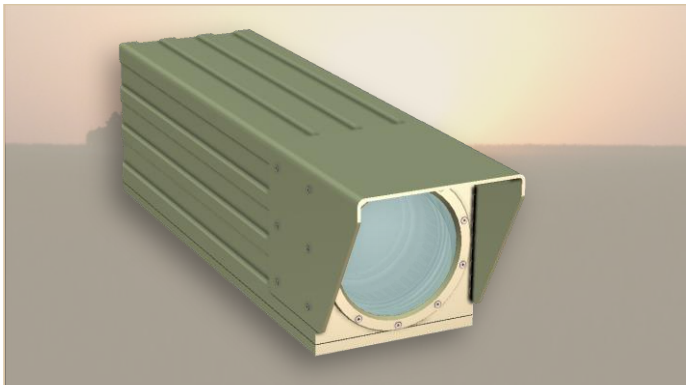

Features

- Zoom lens 30 to 1000 mm (33x)
- High-sensitivity HR-video CCD camera
- Adaptive fog penetration mode
- Graphical overlays
- Oil-free lens construction
- Factory pre-aligned bore sighting
- Configuration by serial interface

Description

The Spectrel OEM 12000/336 is an integrated unit, based on a highly sensitive HR-video colour CCD camera module and a powerful zoom lens, ideal for day/night surveillance for camp perimeter protection, homeland security, critical infrastructure protection (CIP) applications.

It is designed to deliver high-performance images, even under the harshest conditions, in temperatures ranging from -40°C to +70°C.

Optical system

The optical system was developed specifically for use in long range surveillance. It features continuous zoom, with powerful zoom ratio of 30 to 1000 mm, auto-iris and focus adjustment from 3 m to infinity.

The "Auto-Focus on Demand" lets the camera control the focus by the push of a button.

The lens design incorporates oil-free, low-friction surfaces with special coatings, high-speed motors with zero back-lash and high-precision feedback potentiometers. This design was chosen with the objective of meeting the highest standards for precision and accuracy and low failure rates. All lens elements are surface coated for high response throughout the visible spectrum.

Bore sighted

The Spectrel has factory pre-aligned bore sighting, aligned in parallel with the optical reference axis of the system. This simplifies the on-site installation work.

Typical bore sighting deviation is ± 0.2 milliradians, the equivalent to staying within a target area of ± 20 cm, at a distance of 1 km.

External video input

In order to reduce the number of channels required for slipping transmission, the system can support input from an external camera, such as a thermal imaging camera. Switching between the day-time (i.e. Spectrel) and external night-time camera can be manual or automatic.

Graphic overlays

The system has a built-in graphic overlay generator that allows arbitrary graphic overlays to be inserted into the image output. Typical overlays are text strings, showing azimuth, elevation, GPS data or status of weapon systems and symbols, such as hair crosses or other reticles. Programming the graphic overlay engine is done via the RS-422 (or optional CAN-BUS) interface. Graphic overlays can be customized to suit specific user requirements.

Below are typical examples of graphic overlays.

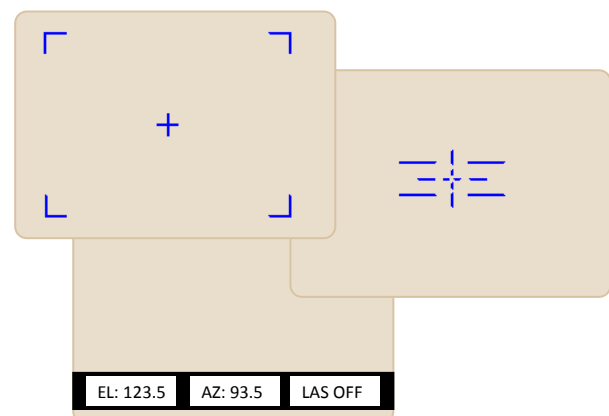

Copenhagen Sensor Technology A/S

Symfonivej 15
DK-2730 Herlev
Denmark

Phone +45 44 92 18 55
Fax +45 44 92 18 56
Web www.copst.com

Document no. L04-000-D02
Revision/Date A / Aug. 2013
Author HS

Spectrel 121000/336

Long-Range Camera System with HR-video Datasheet



Continuous digital zoom

The Spectrel 121000/336 provides continuous digital zoom with 2x range, selectable from the serial interface.

Expanded Hi-Dynamic Range (XDR)

XDR is useful in conditions where there are large variations in brightness in the picture, i.e. when there are very dark and very bright areas in the picture. XDR amplifies the signal level in dark areas and reduces it in very bright areas thereby improving the visibility in the picture.

Fog penetration

The fog penetration function is designed to automatically increase visibility under conditions such as fog, haze and fire smoke. The camera continuously analyses the picture and once it detects a low-contrast condition, it will automatically enhance the contrast.

Digital Noise Reduction (DNR)

The Digital Noise Reduction in the Spectrel 121000/334 camera system is a function that analyses the video image and reduces the noise, particularly in low-light conditions. The analysis is based on a 2- and 3-dimensional algorithm.

Mechanical outline and dimensions

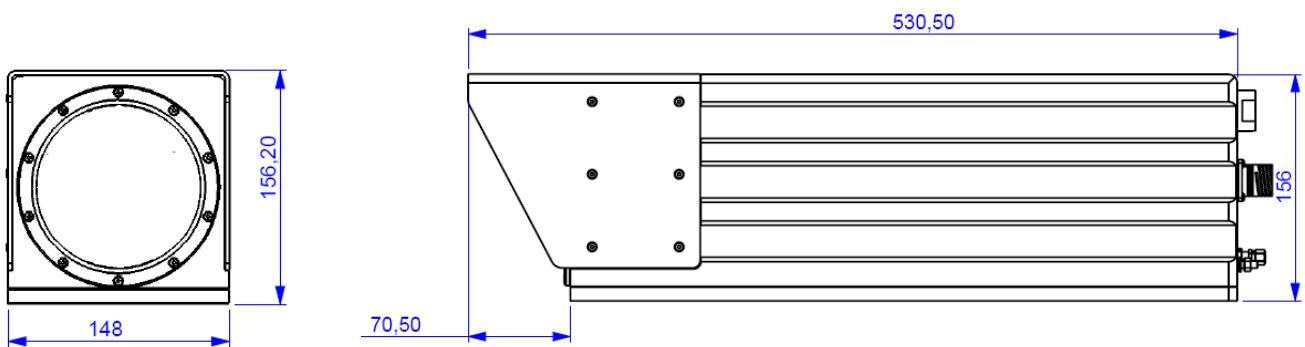

Front View

Side View

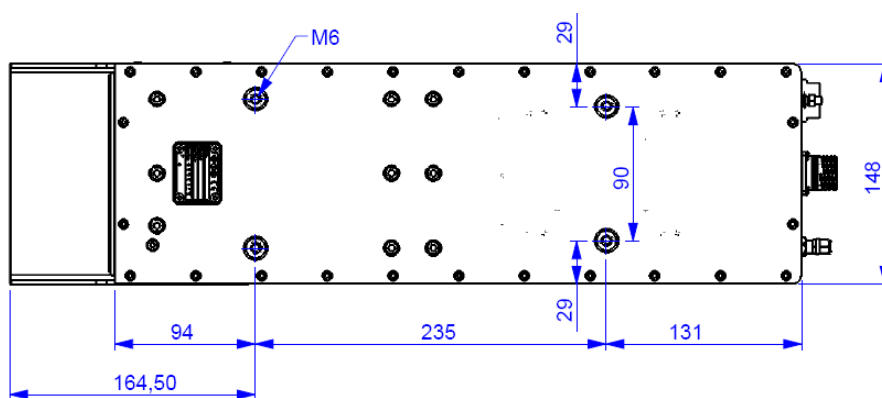

Bottom view

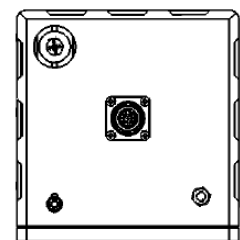

Rear view

Phone: +27 21 975 8894 | Mobile: +27 76 801 3880
Email: sales@ri-tech.co.za | Web: ri-tech.co.za

Rugged interconnect™
TECHNOLOGIES

Copenhagen Sensor Technology A/S

Symfonivej 15
DK-2730 Herlev
Denmark

Phone +45 44 92 18 55
Fax +45 44 92 18 56
Web www.copst.com

Document no. L04-000-D02
Revision/Date A / Aug. 2013
Author HS

Spectrel 121000/336

Long-Range Camera System with HR-video
Datasheet



Specifications

	PAL	NTSC
Camera System		
Sensor	High-sensitivity colour 1/3" CCD sensor with complementary mosaic	
Effective pixels (H x V)	976 x 582	976 x 494
Aspect ratio	4:3	
Video output	Composite CVBS, 1 Vpp, 75 ohm	
System video resolution	540 TVL (15% video modulation, with lens)	
Sensitivity	0,030 Lux, 25% video, F4.5	
Spectral response	Visible + Near IR (Movable IR-cut filter)	
Signal to Noise ratio	> 52 dB, AGC off	
Focal length	30 – 1000 mm zoom (33x)	
Horizontal field of view	Narrow: 0.28° / Wide: 9.3°	
Focus range	3 m to ∞	
Iris range	f/4.5 to 1400 (incl. Spot filter) at WFOV	
Relative aperture	f/4.5 to 9.5 (breakpoint at f=150 mm. Linear between breakpoints)	
Zoom control, travel time	≤ 8 sec. (25°C, both ways, Wide to Narrow FOV)	
Focus control, travel time	≤ 8 sec. (25°C, both ways, 2.5 m to ∞)	
Functions		
Electronic shutter, fixed	1/30 to 1/10,000 sec.	
Gamma correction	0.45 / 0.6 / 1.0	
Automatic Gain Control. range	0 to +36 dB 6DB DGC	
Continuous Digital Zoom	x 2	
White balance	Automatic, Tracking 3 Levels	
Noise reduction	2D and 3D Digital Noise Reduction 3 Levels	
Fog Penetration	Image contrast enhancement	
Auto focus	On demand, Zoom-triggered	
Day/Night mode	Movable IR-cut filter (Colour ↔ Monochrome/Near-IR)	
Graphical overlays	On-screen text and reticles (customizable)	
Configuration, serial interface	RS-422 (optional CAN-BUS) interface(galvanic separation), VISCA/CST protocol	
Mechanical		
Overall dimensions (W x H x L)	148 x 156 x 530.5 mm (not incl. connectors & mounting studs)	
Net weight	< 12 kg	
Housing material	Aluminium with corrosion protection coating	
Protective housing integrity	IP 65	
Connector (power, data, control)	22-pin circular - In accordance with MIL 38999	
Bore-sighting retention	±0.2 milliradians (at the prime horizontal FOV)	
Environmental		
Operating voltage	15 to 36VDC (power supply ground isolated from camera housing)	
Current consumption	< 15W	
Operating temperature	-40°C to +70°C	
Storage temperature	-40°C to +70°C	
Vibration	Wheeled vehicle MIL-STD 810G , method 514.6	
Shock	Transportation: 3 shocks in each direction, 25G @ 6ms	
MTBF	30 000 hours (MIL-HDBK-217-F)	

Copenhagen Sensor Technology A/S

Symfonivej 15
DK-2730 Herlev
Denmark

Phone +45 44 92 18 55
Fax +45 44 92 18 56
Web www.copst.com

Document no. L04-000-D02
Revision/Date A / Aug. 2013
Author HS

Spectrel 121000/336

*Long-Range Camera System with HR-video
Datasheet*



About Us

CST - Copenhagen Sensor Technology A/S is a privately held Danish company specialising in the design and manufacture of high-performance electro-optical solutions for demanding battlefield and surveillance applications.

Founded in 2001, CST has rapidly grown to a mature organisation, capable of serving a global customer base. In modern facilities on the outskirts of Copenhagen, Denmark, CST houses R&D, production, QA and sales and marketing functions. With a collective experience in CCD camera, optics, electronics and software development, the highly skilled staff at CST is committed to creating rugged, durable and innovative electro-optical solutions.

CST is certified to ISO 9001:2008, which applies to the whole process flow of design, development, manufacturing and testing. Furthermore, design and development activities operate in accordance with the ISO 10007:2003 configuration management standard. CST products are not restricted by ITAR.

Customer and OEM solutions

CST has a long tradition of working closely with its customers, identifying unmet needs and creating solutions with sustainable value for the users.

With a strong R&D base at the headquarters in Denmark, CST is able to provide mechanical, optical, software and hardware customisations while meeting the toughest requirements for military, homeland security and high-end surveillance applications.

Whether the need calls for a ruggedized high-precision zoom lens or a highly sensitive CCD camera, or a complete system comprising lens, camera and advanced video processing, CST can offer a fast-track design process. Contact us to discuss your specific requirements. Together we can create a solution that provides the best price and performance ratio.

Copenhagen Sensor Technology A/S

Symfonivej 15
DK-2730 Herlev
Denmark

Phone +45 44 92 18 55
Fax +45 44 92 18 56
Web www.copst.com

Document no. L04-000-D02
Revision/Date A / Aug. 2013
Author HS