

Spectrel 1218/336

Long Range Zoom Camera System Datasheet

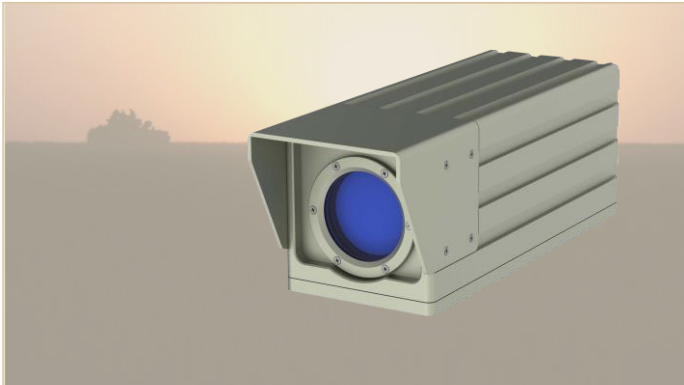

Features

- High colour CCD camera
- True day/night operation
- Zoom lens 11 to 200 mm (18x)
- Oil-free lens construction
- Factory pre-aligned bore sighting
- Graphical overlays
- Configuration by serial interface

Description

The Spectrel 1218/336 System is an integrated unit, based on a highly sensitive colour CCD camera and a powerful zoom lens, ideal for day/night coastal surveillance, camp perimeter protection, protecting sensitive infrastructures and similar applications.

It is designed to deliver high-performance images, even under the harshest conditions, in temperatures ranging from -40°C to +70°C.

Optical system

The optical system was developed specifically for use in long range surveillance. It features continuous zoom, with powerful zoom ratio of 11 to 200 mm, auto-iris and focus adjustment from 1.5 m to infinity.

The "Auto-Focus on Demand" lets the camera control the focus by the push of a button.

The lens design incorporates oil-free, low-friction surfaces with special coatings, high-speed motors with zero back-lash and high-precision feedback potentiometers. This design was chosen with the objective of meeting the highest standards for precision and accuracy and low failure rates. All lens elements are surface coated for high response throughout the visible spectrum.

Bore sighted

The Spectrel 1218/336 has factory pre-aligned bore sighting, aligned in parallel with the optical reference axis of the system. This makes for easy on-site installation.

Typical bore sighting deviation is ± 0.2 milliradians, the equivalent to staying within a target area of ± 20 cm, at a distance of 1 km.

True Day/Night mode operation

The Spectrel 1218/336 has an integrated movable IR-cut filter that allows capture of colour images with high image fidelity during day-time and crisp monochrome images during low light level conditions. In night mode operation the IR-cut filter is moved out of the optical path, with increased sensitivity (also in Near-IR) as a result

Graphic overlays

The system has a built-in graphic overlay generator that allows arbitrary graphic overlays to be inserted into the image output. Typical overlays are text strings, showing azimuth, elevation, GPS data or status of weapon systems and symbols, such as hair crosses or other reticles.

Programming the graphic overlay engine is done via the RS-422 / CAN-BUS interface. Graphic overlays can be customized to suit specific user requirements.

Below are typical examples of graphic overlays.

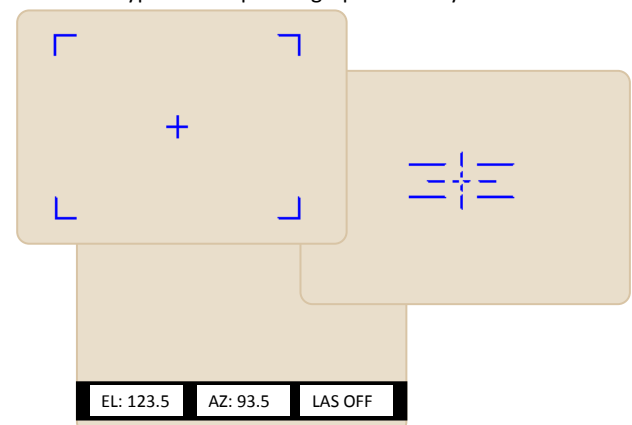

Copenhagen Sensor Technology A/S

Symfonivej 15
DK-2730 Herlev
Denmark

Phone +45 44 92 18 55
Fax +45 44 92 18 56
Web www.copst.com

Document no. F04-006-D09
Revision A / Aug. 2013
Author HS

Spectrel 1218/336

Long Range Zoom Camera System Datasheet



Fog penetration

The fog penetration function is designed to automatically increase visibility under conditions such as fog, haze and fire smoke. The camera continuously analyses the picture and once it detects a low-contrast condition, it will automatically enhance the contrast.

Expanded Hi-Dynamic Range (XDR)

XDR is useful in conditions where there are large variations in brightness in the picture, i.e. when there are very dark

and very bright areas in the picture. XDR amplifies the signal level in dark areas and reduces it in very bright areas thereby improving the visibility in the picture.

Digital Noise Reduction (DNR)

The Digital Noise Reduction in the Spectrel 1218/336 camera system is a function that analyses the video image and reduces the noise, particularly in low-light conditions. The analysis is based on a 2- and 3-dimensional algorithm.

Mechanical outline and dimensions

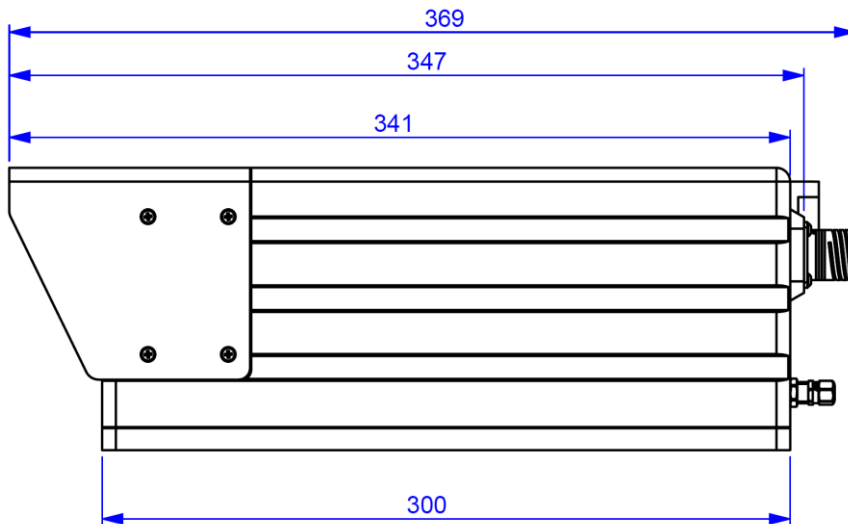

Side View

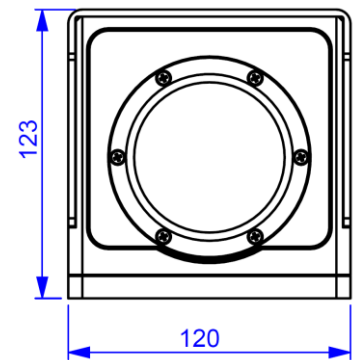

Front View

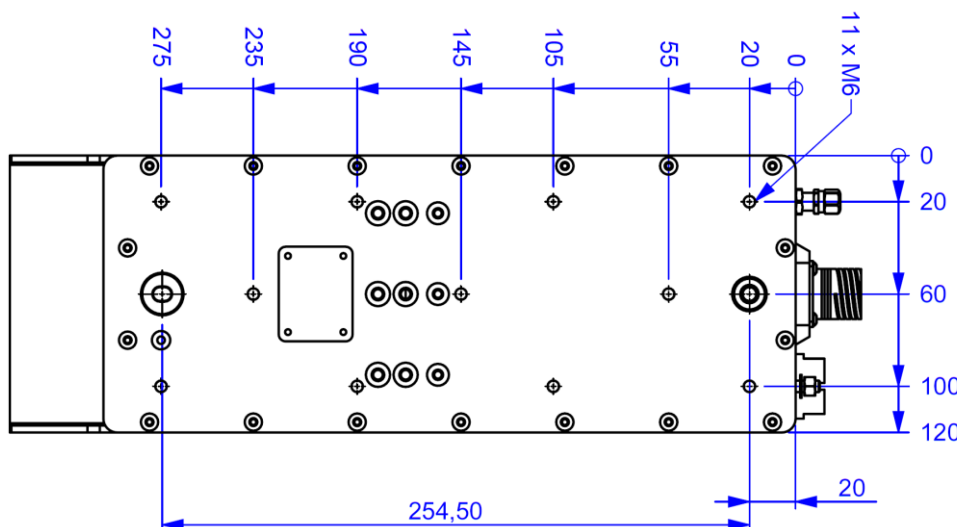

Bottom view

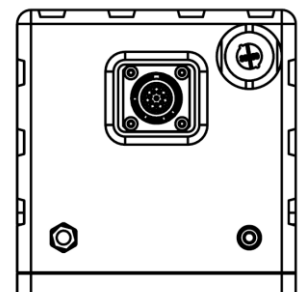

Rear view

Copenhagen Sensor Technology A/S

Symfonivej 15
DK-2730 Herlev
Denmark
Phone +45 44 92 18 55
Fax +45 44 92 18 56
Web www.copst.com

Document no. F04-006-D09
Revision A / Aug. 2013
Author HS

Spectrel 1218/336

Long Range Zoom Camera System Datasheet



Specifications

	PAL	NTSC
Camera System		
Sensor	High sensitivity 1/3" CCD sensor with complementary mosaic	
Effective pixels (H x V)	976 x 582	976 x 494
Aspect ratio	4:3	
Video output	Composite CVBS, 1 Vpp, 75 ohm	
Video resolution, CVBS	> 500 TVL at 8° Hor. FOV; > 475 TVL at 1.7° Hor. FOV (25% video)	
Sensitivity	0,020 Lux, 25% video, F1.9, WFOV, No IR-cut filter	
Spectral response	Switchable between visible only (colour) and visible + NIR (monochrome)	
Signal to Noise ratio	> 52 dB, AGC off	
Scanning system	2:1 Interlace	
Horizontal frequency	15.625 kHz	15.734 kHz
Vertical frequency	50 Hz	59.94 Hz
Focal length	11 – 200 mm zoom (18x)	
Field of view	Narrow: Hor. 1.4°, Vert. 1°, / Wide: Hor. 25°, Vert. 19°	
Focus range	1.5 m to ∞	
Iris range	f/1.9 to 1400 (incl. Spot filter)	
Zoom control, travel time	≤ 5 sec. (25°C, both ways, Wide to Narrow FOV)	
Focus control, travel time	≤ 8 sec. (25°C, both ways, 1.5 m to ∞)	
Functions		
Electronic shutter, fixed	1/50 to 1/40,000 sec.	1/60 to 1/40,000 sec.
Gamma correction	0.45 / 1.0	
Automatic Gain Control. range	Max 36 DB Analog + 6 DB DGC	
Continuous Digital Zoom	x 2	
White balance	Automatic, Tracking	
True day/night mode	Movable IR-cut filter for proper colour (day) and Monochr. + NIR (night) rendering	
Lens Iris control	Automatic	
Integration mode	Up to 64 fields exposure time, for low light level imaging	
Noise reduction	2D and 3D Digital Noise Reduction 3 Levels	
Fog Penetration	Image contrast enhancement 3 Levels	
Auto focus	On demand, Zoom-triggered	
Zoom/Focus control	Zoom: Wide/Tele/Speed, Focus: Near/Far/Speed	
Video overlays	On screen text and reticles (customizable)	
Configuration, serial interface	RS-422 (optional CAN-BUS) interface(galvanic separation), VISCA/CST protocol	
Mechanical		
Overall dimensions (W x H x L)	120 x 123 x 341 mm (not incl. connectors & mounting studs)	
Net weight	< 6 kg	
Housing material	Aluminium with corrosion protection coating	
Protective housing integrity	IP 65 (or better)	
Connector (power, data, control)	22-pin circular - In accordance with MIL 38999	
Bore-sighting retention	±0.2 milliradians (at the prime horizontal FOV)	
Environmental		
Operating voltage	18 to 32 VDC (power supply ground isolated from camera housing)	
Power consumption	< 15 W	
Operating temperature	-40°C to +70°C	
Storage temperature	-40°C to +70°C	
MTBF	30 000 hours (MIL-HDBK-217-F)	

Phone: +27 21 975 8894 | Mobile: +27 76 801 3880
Email: sales@ri-tech.co.za | Web: ri-tech.co.za

Rugged Interconnect™
TECHNOLOGIES

Copenhagen Sensor Technology A/S

Symfonivej 15 Phone +45 44 92 18 55
DK-2730 Herlev Fax +45 44 92 18 56
Denmark Web www.copst.com

Document no. F04-006-D09
Revision A / Aug. 2013
Author HS

Spectrel 1218/336

*Long Range Zoom Camera System
Datasheet*



About Us

CST - Copenhagen Sensor Technology A/S is a privately held Danish company specialising in the design and manufacture of high-performance electro-optical solutions for demanding battlefield and surveillance applications.

Founded in 2001, CST has rapidly grown to a mature organisation, capable of serving a global customer base. In modern facilities on the outskirts of Copenhagen, Denmark, CST houses R&D, production, QA and sales and marketing functions. With a collective experience in CCD camera, optics, electronics and software development, the highly skilled staff at CST is committed to creating rugged, durable and innovative electro-optical solutions.

CST is certified to ISO 9001:2008, which applies to the whole process flow of design, development, manufacturing and testing. Furthermore, design and development activities operate in accordance with the ISO 10007:2003 configuration management standard. CST products are not restricted by ITAR.

Customer and OEM solutions

CST has a long tradition of working closely with its customers, identifying unmet needs and creating solutions with sustainable value for the users.

With a strong R&D base at the headquarters in Denmark, CST is able to provide mechanical, optical, software and hardware customisations while meeting the toughest requirements for military, homeland security and high-end surveillance applications.

Whether the need calls for a ruggedized high-precision zoom lens or a highly sensitive CCD camera, or a complete system comprising lens, camera and advanced video processing, CST can offer a fast-track design process. Contact us to discuss your specific requirements. Together we can create a solution that provides the best price and performance ratio.

Copenhagen Sensor Technology A/S

Symfonivej 15
DK-2730 Herlev
Denmark

Phone +45 44 92 18 55
Fax +45 44 92 18 56
Web www.copst.com

Document no. F04-006-D09
Revision A / Aug. 2013
Author HS